

morsø

By appointment to The Royal Danish Court

morsø

- Ⓚ **Montering af varmelagring**
- Ⓓ **Montierung vom Wärmespeicher**
- Ⓤ **Installation of heat storage**
- Ⓝ **Montering av varmelagring**
- Ⓢ **Montering av värmelagring**
- ⓕ **Montage de l'accumulateur de chaleur**
- Ⓝ **Montage van warmte-opslag**
- Ⓢ **Instalación de acumulación de calor**
- Ⓜ **Installazione degli accumulatori di calore**

Montering af varmelagring til Morsø 6191, 6192, 7691, 7692

1. Den øverste støbte topplade, der ligger løst på ovnen fjernes/løftes af.



Bagudgang



Topudgang

2. To bolte med skiver afmonteres to-prammen.



Bagudgang



Topudgang

3. De to afmonterede bolte med skiver bruges nu til montering af top-modulet.

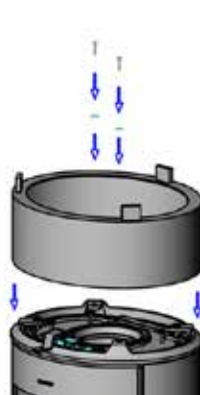

Bagudgang

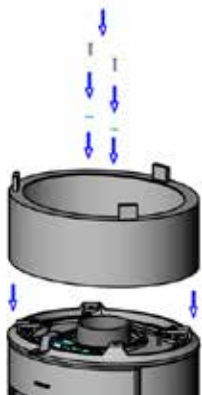

Topudgang

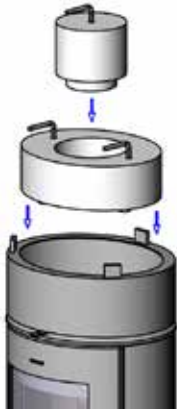

Bagudgang med lavt topmodul



Topudgang med lavt topmodul

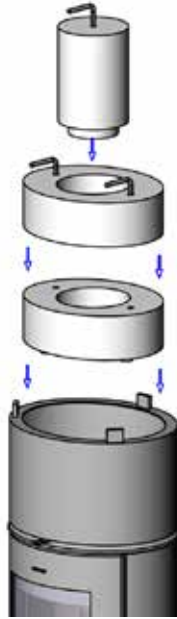

Bagudgang med højt topmodul

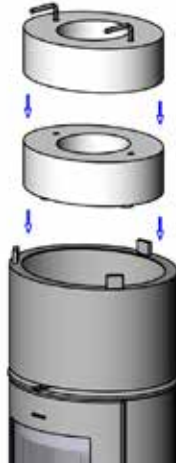

Topudgang med højt topmodul

4. De to medfølgende greb bruges kun ved løft og nedsenkning af varmelagringsstenene. Efter nedsænkningen af varmelagringsstenene fjernes grebene og skal ikke bruges mere.

5. De samlede reguleringsplader placeres så de falder i hak ved de tre ben på topmodulet. Reguleringspladerne er konstrueret så reguleringsgrebet kan placeres i højre eller venstre side. Ved røgafgang ovenud fjernes brikken i midten. De tre små broer savnes evt. over med en klinge fra en nedstryger.

Til sidst lægges toppladen på plads, så den kommer til at hvile på de tre ben på topmodulet.

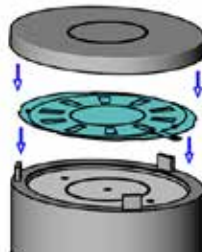

Bagudgang

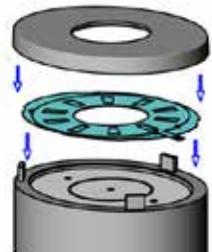

Topudgang

Montierung vom Wärmespeicher bei den Morsø-Modellen 6191, 6192, 7691, 7692

1. Die Deckplatte aus Gusseisen, die lose zuoberst auf dem Ofen liegt, entfernen/wegheben.



Abgang hinten



Abgang oben

2. Die 2 Bolzen mit Scheiben werden vom Toprahmen abmontiert.



Abgang hinten

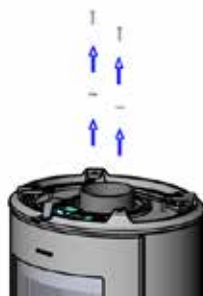

Abgang oben

3. Die abmontierten Bolzen mit Scheiben werden jetzt für die Montage des Topmoduls benutzt.

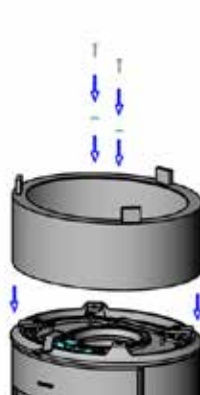

Abgang hinten

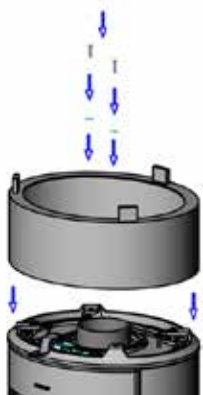

Abgang oben

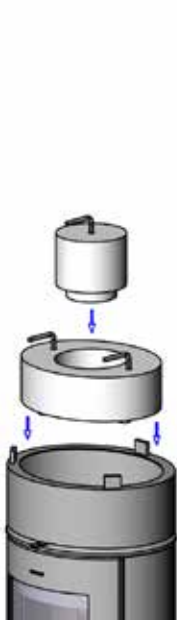

**Abgang nach hinten
mit niedrigem
Topmodul**



**Abgang nach oben
mit niedrigem
Topmodul**

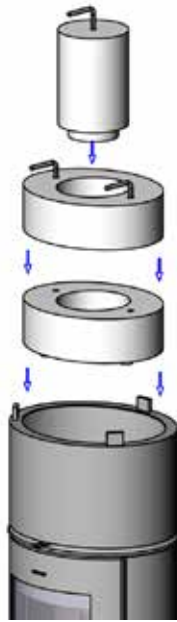

**Abgang nach
hinten mit hohem
Topmodul**

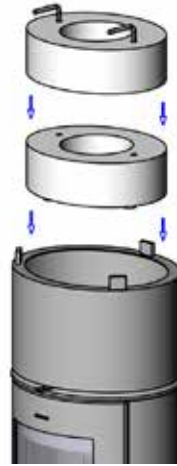

**Abgang nach
oben mit hohem
Topmodul**

4. Die beiden mitgelieferten Griffe werden nur zum Anheben und zum Einlegen der Wärmespeichersteine verwendet. Nach dem Einlegen der Wärmespeichersteine sind die Griffe zu entfernen und werden in der Folge nicht mehr verwendet.

5. Die zusammengefügte Regulierungsplatten so platzieren, dass sie bei den drei Zacken auf dem Topmodul einrasten.

Die Regulierungsplatten sind so konstruiert, dass der Regulationsgriff auf der rechten oder der linken Seite angebracht werden kann.

Beim Rauchabzug nach oben ist das Mittelteil zu entfernen. Die drei kleinen Brücken können ev. mit der Klinge einer Metallsäge abgesägt werden. Schließlich muss die Deckplatte so montiert werden, dass sie auf den drei Zacken des Topmoduls ruht.

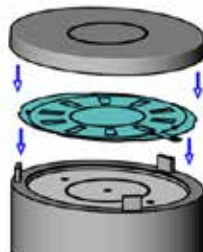

Angang hinten

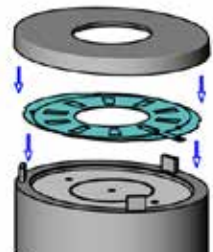

Abgang oben

Installation of heat storage for Morsø 6191, 6192, 7691, and 7692

1. The upper cast-iron top cover lying loosely on the stove is removed/lifted off.



Flue to the rear



Flue upwards

2. As you face the stove, remove the rear left hand and front right hand bolts and washers from the top retaining ring.



Flue to the rear



Flue upwards

3. Locate the heat store and secure using the two previously removed bolts and washers.

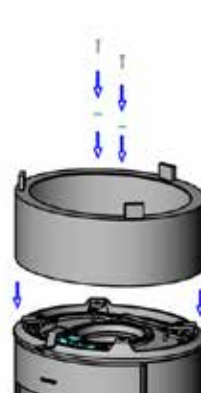

Flue to the rear

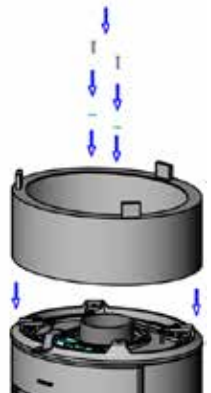

Flue upwards

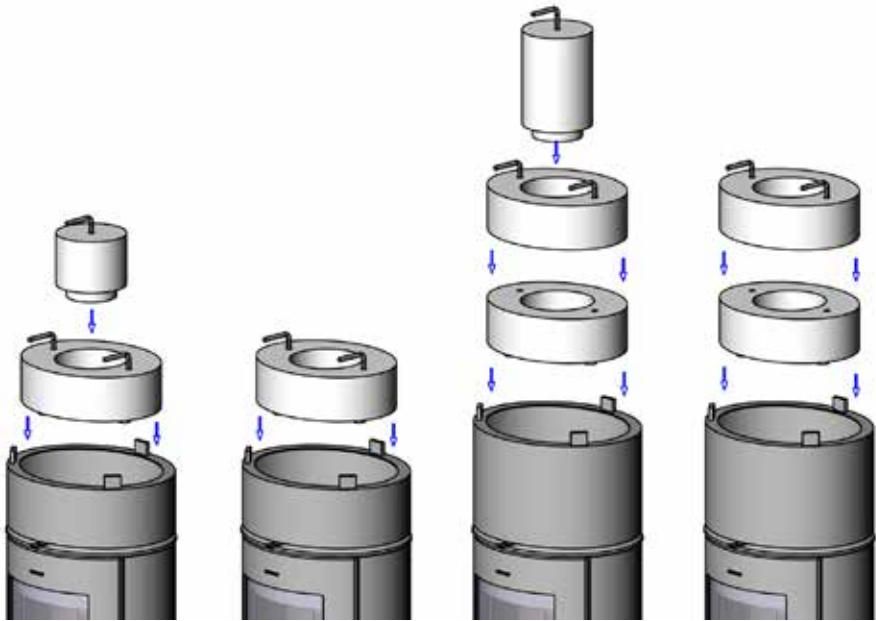

Flue to the rear with a low top module

Flue upwards with a low top module

Flue to the rear with a tall top module

Flue upwards with a tall top module

4. The two handles (included) are only used for lifting and lowering the heat storage elements. The handles are removed after the heat accumulation elements have been lowered in place. They will not be needed again.

5. The regulator disk assembly is positioned so that it falls in place with the three legs on the top module. The regulator disks are constructed so that the regulation lever may be placed to the right or to the left. When the flue is upwards, the centre piece must be removed. The three small bridges may be cut with a hack-saw blade.

Finally, the top cover is put in place so that it rests on the three legs on the top module.

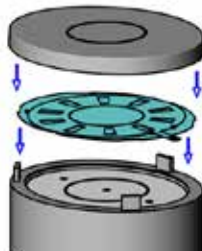

Flue to the rear

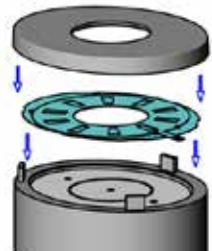

Flue upwards

Montering av varmelagring til Morsø 6191, 6192, 7691, 7692

1. Fjern/løft av den øverste støpte topplaten, som ligger løst på ovennen.



Røykavgang bak



Røykavgang oppå

2. To bolter med skiver avmonteres topprammen.



Røykavgang bak



Røykavgang oppå

3. De to demonterte bolter med skiver blir nå brukt til å montere topmodulen.

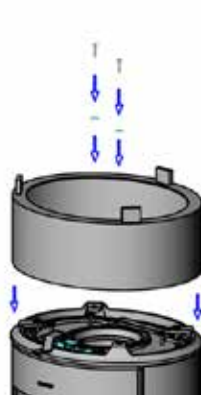

Røykavgang bak

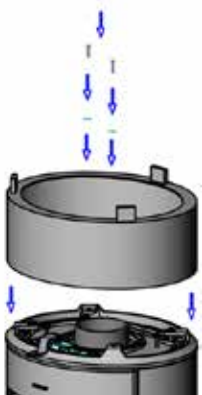

Røykavgang oppå

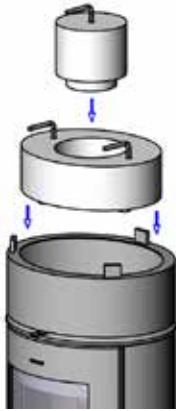

**Røykavgang
bak med lav
toppmodul**

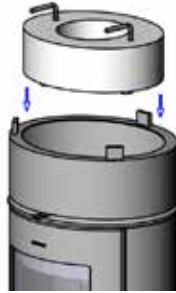

**Røykavgang
oppå med lav
toppmodul**

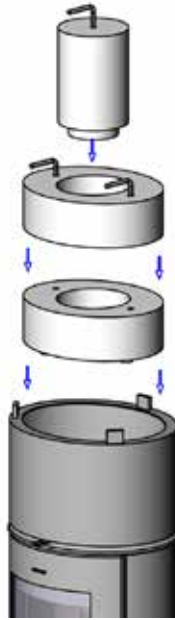

**Røykavgang
bak med høy
toppmodul**

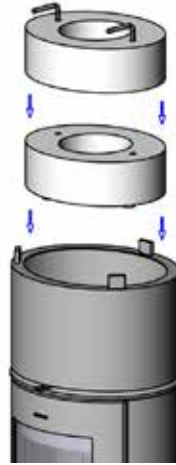

**Røykavgang
oppå med høy
toppmodul**

4. De to medfølgende håndtakene brukes kun til løft og nedsenking av varmelagingssteinene. Etter nedsenkingen av steinene fjernes håndtakene og skal ikke brukes mer.

5. Reguleringsplatene plasseres deretter slik at de senkes på plass ved de tre knastene i toppmodulen. Reguleringsplatene er konstruert slik at reguleringshåndtaket kan plasseres til høyre eller venstre. Ved røykavgang oppå fjernes briken i midten. De tre små broene kappes eventuelt med en baufil. Til slutt legges topplaten på plass, slik at den hviler på de tre knastene i toppmodulen.

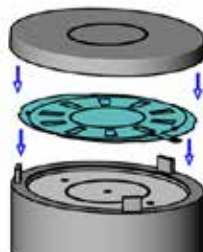

Røykavgang bak

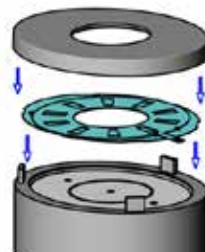

Røykavgang oppå

Montering av värmelagring för Morsø 6191, 6192, 7691, 7692

1. Lyft av den översta gjutna topplåten som ligger löst på kaminen.



Bakanslutning



Toppanslutning

2. Två bultar med brickor monterar av toppramen.



Bakanslutning



Toppanslutning

3. De två bultarna med brickor används nu till montering av toppmodulen.

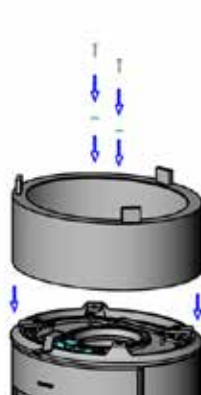

Bakanslutning

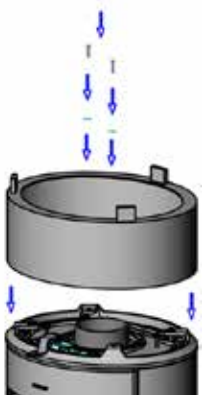

Toppanslutning

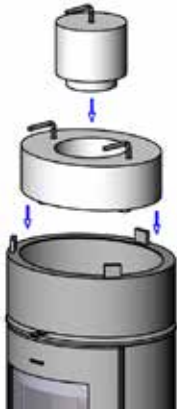

Bakanslutning med låg toppmodul



Toppanslutning med låg toppmodul

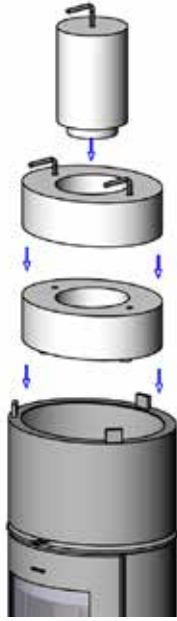

Bakanslutning med hög toppmodul

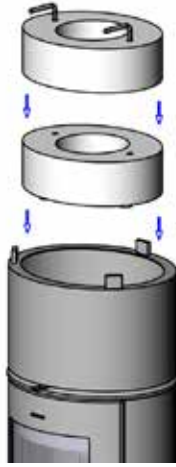

Toppanslutning med hög toppmodul

4. De två medföljande handtagen ska bara användas vid lyft och nedsänkning av värmelagringsstenarna. När värmeackumuleringsstenarna sänkts ned ska handtagen tas bort och inte användas mer.

5. Placera de samlade regulatorplåtarna så att de fäster vid de tre benen på toppmodulen.

Regulatorplåtarna är konstruerade så att regulatorhandtaget kan placeras på höger eller vänster sida. Vid rökavgång uppåt ska brickan i mitten tas bort. Såga eventuellt av de tre små bryggorna med en bågfil. Lägg till sist topplåten på plats så att den vilar på de tre benen på toppmodulen.

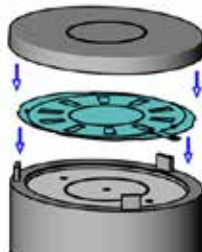

Bakanslutning

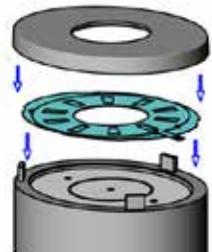

Toppanslutning

Montage de l'accumulateur de chaleur, Morsø 6191, 6192, 7691, 7692

1. Soulevez et retirez la plaque supérieure en fonte posée sur le poêle sans être fixée.



Échappement sur l'arrière



Échappement sur le dessus

2. Démontez deux boulons avec rondelles de la plaque supérieure.



Échappement sur l'arrière



Échappement sur le dessus

3. Utilisez maintenant les deux boulons avec rondelles démontés pour la fixation du module supérieur.

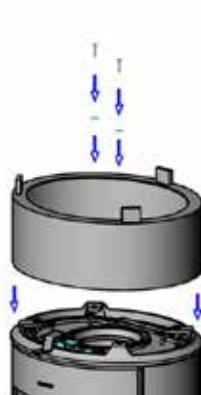

Échappement sur l'arrière

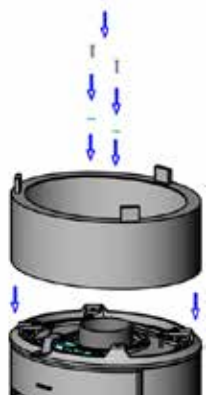

Échappement sur le dessus

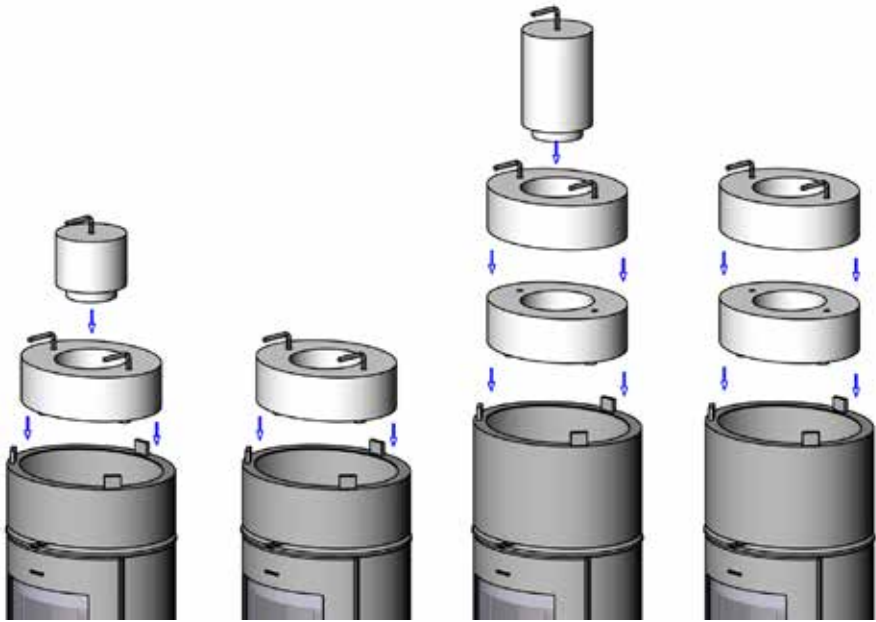

Échappement sur l'arrière avec module supérieur bas

Échappement sur le dessus avec module supérieur bas

Échappement sur l'arrière avec module supérieur haut

Échappement sur le dessus avec module supérieur haut

4. Les deux poignées fournies sont utilisées uniquement pour soulever ou abaisser les pierres à accumulation de chaleur. Après avoir abaissé les pierres à accumulation de chaleur, retirez les poignées qui ne doivent plus être utilisées.

5. Placez les plaques de régulation assemblées de manière à ce qu'elles s'emboîtent avec les trois ergots sur le module supérieur.

Les plaques de régulation sont conçues de manière à ce que la poignée de régulation puisse être placée du côté droit ou du côté gauche.

Avec la sortie de fumée sur le dessus, retirez la brique du milieu.

Sciez éventuellement les trois petits ponts avec une scie à métaux.

Pour terminer, posez la plaque supérieure de manière à ce qu'elle repose sur les trois ergots du module supérieur.

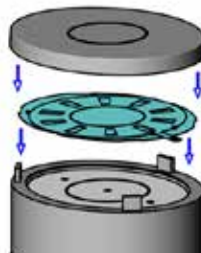

Échappement sur l'arrière

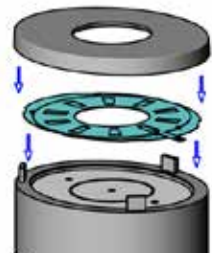

Échappement sur le dessus

Montage van warmte-opslag voor Morsø 6191, 6192, 7691, 7692

1. Verwijder de bovenste gegoten bovenplaat, die los op de kachel ligt, door hem op te tillen.



Achteruitgang



Bovenuitgang

2. Schroef de twee bouten en de onderlegingen los van het bovenkamer.



Achteruitgang



Bovenuitgang

3. Gebruik nu de twee losgeschroefde bouten en onderlegingen om de bovenmodule te monteren.

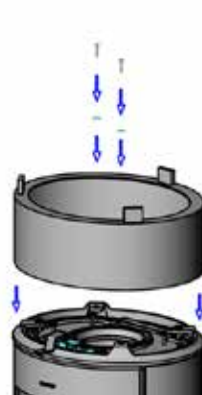

Achteruitgang

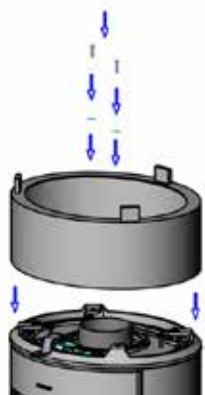

Bovenuitgang

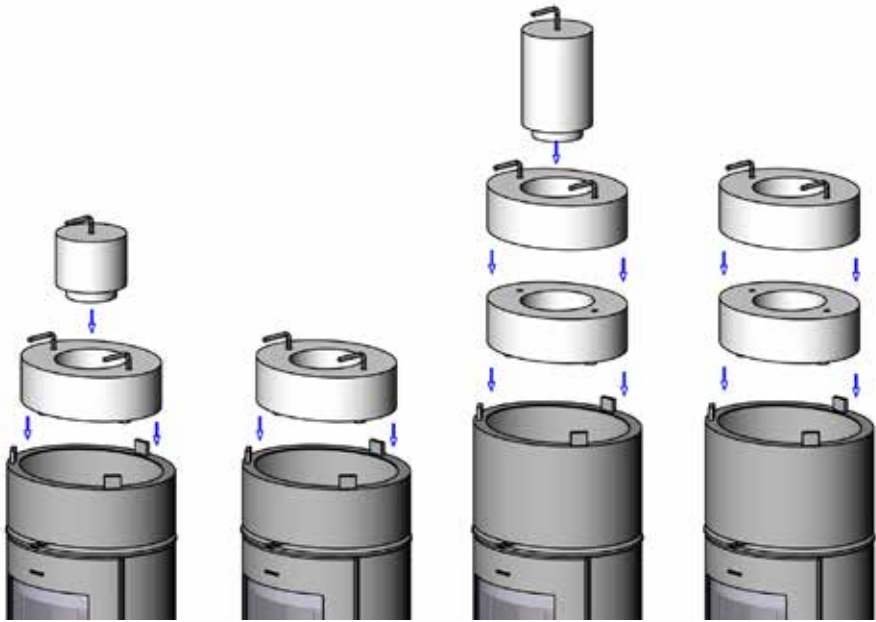

Achteruitgang met lage bovenmodule

Bovenuitgang met lage bovenmodule

Achteruitgang met hoge bovenmodule

Bovenuitgang met hoge bovenmodule

4. Gebruik de twee meegeleverde grepen alleen bij het optillen en laten zakken van de warmteaccumulatiestenen. Na het neerlaten van de warmteaccumulatiestenen worden de grepen verwijderd en niet meer gebruikt.

5. De geassembleerde regelplaten worden zo geplaatst dat ze overeenstemmen met de drie poten van de bovenmodule.

De regelplaten zijn zo ontworpen dat de regelhefboom zowel links als rechts kan worden aangebracht.

Bij de rookuitgang naar boven moet de middenring verwijderd worden.

Eventueel kunt u de drie kleine bruggen afzagen met een ijzerzaagblad. Leg ten slotte de bovenplaat op de juiste plek, zodat hij rust op de drie poten van de bovenmodule.

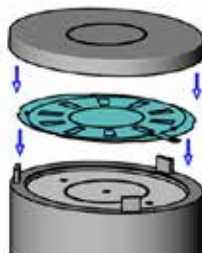

Achteruitgang

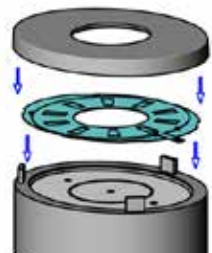

Bovenuitgang

Instalación de acumulación de calor los modelos Morsø 6191, 6192, 7691 y 7692

1. Se retira/levanta la tapa superior de fundición que está apoyada sin fijar en la parte de arriba.

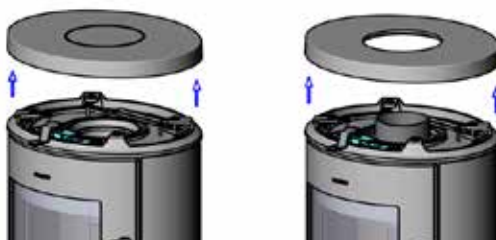

Salida de gases trasera Salida de gases superior

2. Los dos tornillos y sus arandelas se desatornillan de la pieza superior.

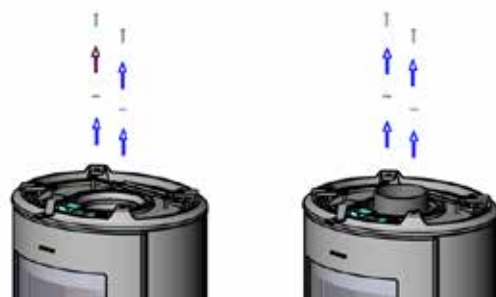

Salida de gases trasera Salida de gases superior

3. Los dos tornillos que antes se han desatornillado junto con sus arandelas se usan hora para montar el módulo superior.

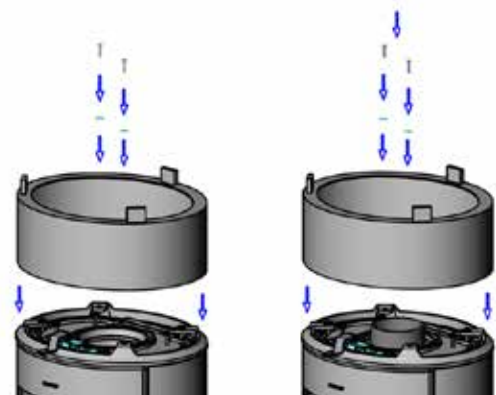

Salida de gases trasera Salida de gases superior

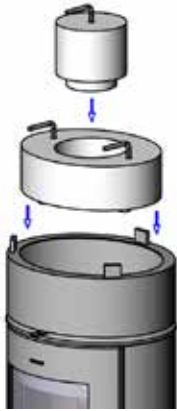

Salida de gases trasera con módulo superior bajo



Salida de gases superior con módulo superior bajo

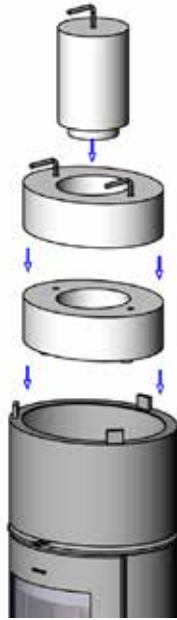

Salida de gases trasera con módulo superior alto

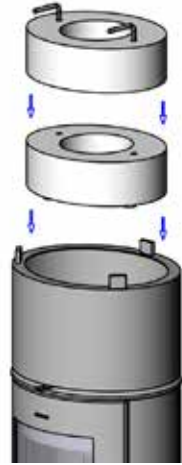

Salida de gases superior con módulo superior alto

4. Las dos asas (incluidas) solamente se usan para levantar y bajar los elementos de acumulación de calor. Una vez que los elementos de acumulación de calor se han bajado hasta su posición, se quitan las asas. Ya no se volverán a necesitar.

5. El conjunto del disco regulador se coloca de tal manera que queda en su posición con las tres patas en el módulo superior.

Gracias al diseño de los discos reguladores, la palanca de regulación puede colocarse a la derecha o a la izquierda. Cuando la salida de gases es por arriba, se debe quitar la pieza central. Los tres pequeños puentes se pueden cortar con una hoja de sierra de arco. Finalmente, la tapa superior se coloca en su lugar de manera que quede descansado sobre las tres patas del módulo superior.

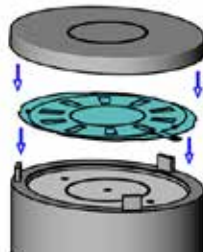

Salida de gases trasera

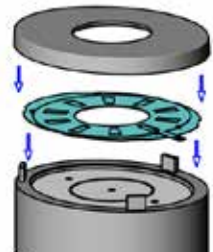

Salida de gases superior

Installazione degli accumulatori di calore per I modelli Morsø 6191, 6192, 7691 e 7692

1. Rimuovere/sollevere il top superiore in ghisa appoggiato sulla stufa.



Uscita posteriore



Uscita superiore

2. Svitare i due dadi e le rondelle dalla cornice superiore.



Uscita posteriore



Uscita superiore

3. Utilizzare ora i dadi e le rondelle che sono stati svitati per montare il modulo superiore.

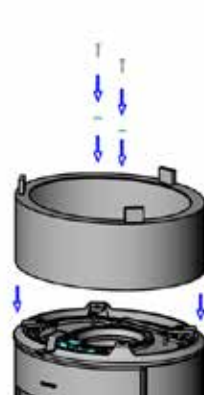

Uscita posteriore

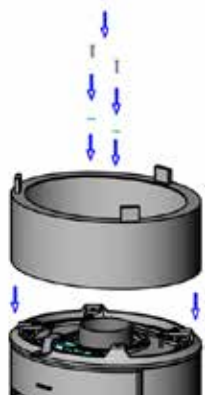

Uscita superiore

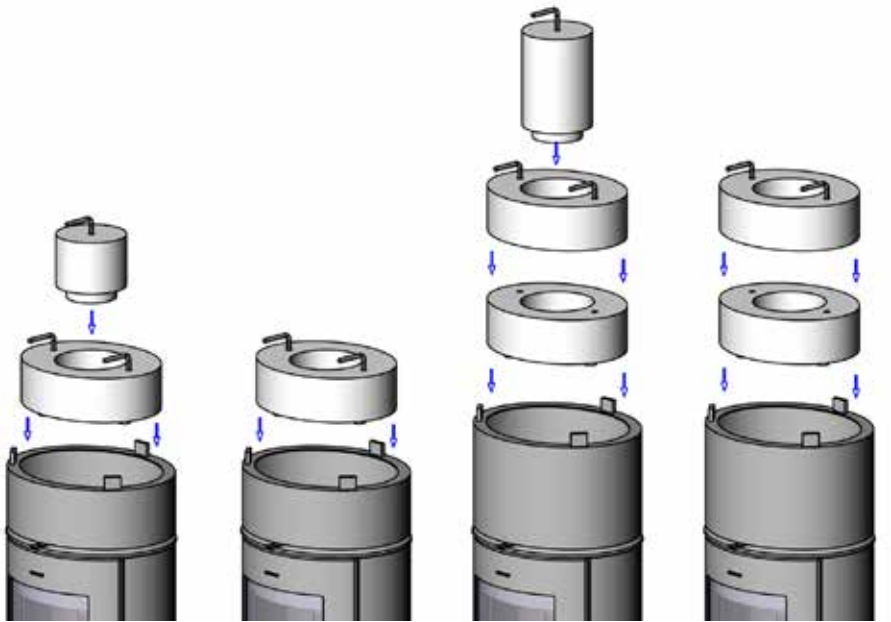

**Uscita posteriore
con modulo top
basso**

**Uscita superiore
con modulo top
basso**

**Uscita posteriore
con modulo top alto**

**Uscita superiore
con modulo top alto**

4. Le due manopole (incluse) vanno usate solo per sollevare e abbassare gli elementi di accumulo del calore e vanno rimosse una volta che gli elementi siano stati posizionati perché non dovranno essere più utilizzate.

5. L'assemblaggio del disco regolatore va eseguito in modo che si posizioni con le tre tacche davanti alle gambine del modulo top.

I dischi regolatori sono fabbricati in modo da posizionare la levetta di regolazione sia sulla destra che sulla sinistra.

Quando la fuoriuscita di fumo è verso l'alto, il dischetto centrale deve essere rimosso.

I tre ponticelli possono essere accorciati con un seghetto.

Alla fine, rimettere a posto la parte superiore appoggiandola sulle tre gambine del modulo top.

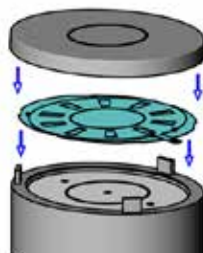

Uscita posteriore

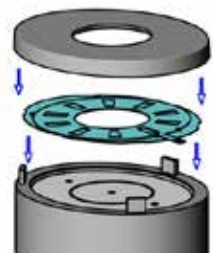

Uscita superiore



By appointment to The Royal Danish Court

morsø

Morsø Jernstøberi A/S - 08.12.2015 - 72612900

MORSØ JERNSTØBERI A/S . DK-7900 NYKØBING MORS
E-Mail: stoves@morsoe.com · Website: www.morsoe.com