

morsø



By appointment to The Royal Danish Court

**morsø**

# Instructions for installation and use

## 7800 & 7900

Designed by Monica Ritterband

**Morsø 7840, 7843, 7848, 7850, 7870, 7890**

**Morsø 7940, 7943, 7948, 7950, 7970, 7990**



**EN 13240 · NS 3058-3059**

MORSØ JERNSTØBERI A/S · DK-7900 NYKØBING MORS  
E-Mail: [info@morsoe.com](mailto:info@morsoe.com) · Website: [www.morsoe.com](http://www.morsoe.com)

## Enjoy your new Morsø stove!

**Morsø, the biggest stove company in the Danish market, has been making wood-burning stoves of the highest quality since 1853. Just follow the instructions below, and we are certain that you will be able to use and enjoy your new stove for many years to come.**

<b>1.0</b>	<b>Installing your Morsø stove</b>	<b>3</b>
	1.1 Unpacking the stove	3
	1.2 Installing the stove	3
	1.3 Chimney sweep	3
	1.4 Location of the stove/distance requirements	3
	1.5 The chimney	5
	1.6 Pipe connections	6
	1.7 Connecting to a brick chimney	7
	1.8 Connecting to a steel chimney	7
	1.9 Draught	9
<b>2.0</b>	<b>Firing/using the stove</b>	<b>10</b>
	2.1 Lighting instructions and fuelling intervals	11
<b>3.0</b>	<b>Routine stove maintenance</b>	<b>15</b>
	3.1 External maintenance	15
	3.2 Internal maintenance	15
	3.3 Cleaning the stove	16

### Additional accessories

We offer a comprehensive line of chimney, floor plate and accessory products that can facilitate the daily operation and maintenance of your Morsø stove.

Likewise, for this stove we have developed a range of accessories designed by Monica Ritterband.

### Cast iron

Cast iron is a live material. There are no two ovens that are identical. This is partly due to the tolerances of the casting process, partly because the ovens are a work of craftsmanship. Minor unevennesses may also occur in the cast iron surface.

## 1.0 Installing your Morsø stove

### 1.1 Unpacking the stove

The cast-iron basic stove is supplied ready for fitting the selected pedestal and upper section. The Morsø 7800/7900 series weighs between 160 and 280 kg. To avoid damage during unpacking and assembling the stove, we recommend that two people carry out this work. Remove the cardboard packaging, then lift the cast-iron top plate which is lying loose off the stove before lifting the stove off the wooden pallet. While fitting the selected pedestal, which is supplied separately, lie the stove on its back, if possible with the cardboard packaging as a protective layer. Once assembled, lift the stove up and place it carefully where it is to be permanently located, so that the pipes can be installed. If the stove is to stand on flammable material, place it centrally on a base plate made of steel, glass or other non-flammable material. Before lighting for the first time, check that all the internal parts have been positioned correctly. The packaging can be disposed of according to the applicable waste disposal regulations.

### 1.2 Installing the stove

National and local regulations regarding the installation of wood-burning stoves must be observed, as must local regulations regarding chimney connections and chimney installation. You may want to ask your chimney sweep for advice. However, it is you, your technical adviser or workman, who is responsible for compliance with the applicable national and local regulations.

### 1.3 Chimney sweep

As stated, it may be wise to consult your local chimney sweep before installing the stove. In any event, the chimney sweep must be notified once the wood-burning stove has been installed. The chimney sweep will inspect the installation, and reach an agreement with you regarding sweeping intervals. If your chimney has not been used for some time, it should be inspected for cracks, bird nests, etc., before it is used.

### 1.4 Location of the stove/distance requirements

Distance requirements apply only if the stove is placed near flammable materials. Your new stove can be positioned as specified on the authorisation sign on the back of the stove if the walls are made of flammable material.

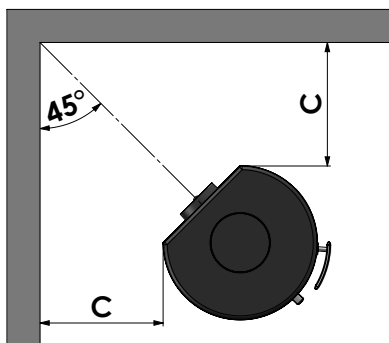
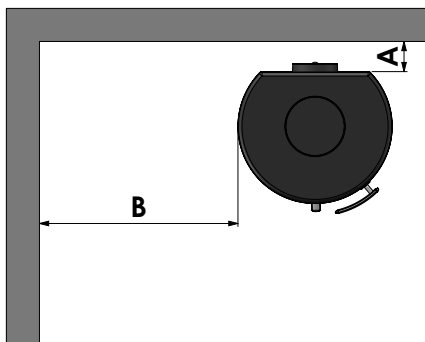

## Minimum distance to combustible material:

### Morsø 7800

Installation	Stove type	Distance A	Distance B	Distance C	Distance front of stove
Normal Parallel	Morsø 7800 un-insulated pipe	125 mm.	400 mm.	-	800 mm
Normal Parallel	Morsø 7800 insulated pipe	50 mm.	400 mm.	-	
Corner	Morsø 7800 un-insulated pipe	-	-	150 mm.	

### Morsø 7900

Installation	Stove type	Distance A	Distance B	Distance C	Distance front of stove
Normal Parallel	Morsø 7900 un-insulated pipe	125 mm.	700 mm.	-	900 mm
Normal Parallel	Morsø 7900 insulated pipe	50 mm.	700 mm.	-	
Corner	Morsø 7900 un-insulated pipe	-	-	350 mm.	

We recommend that the stove be installed at least 10 - 15 cm from masonry, in order to allow heat to circulate and to facilitate the cleaning of the inside and outside of the stove. A layer of wallpaper on a brick wall is normally viewed as non-flammable material.

### The floor

If the stove is installed on a flammable floor, national and local regulations must be observed with regard to the size of the non-flammable underlying surface that must cover the floor beneath the stove. The underlying surface must naturally be able to bear the weight of the stove and, if applicable, the steel chimney.

### Distance to furniture

The minimum clearance to combustible materials in front of the stove is 800 mm. for Morsø 7800 and 900 mm. for Morsø 7900. The minimum distance to combustible materials must be observed; furthermore, it should be considered whether furniture and other items will dry out if placed near the stove.

A wood-burning stove gets hot when it is fired. Caution must therefore be observed, particularly with regard to children touching the stove.

## 1.5 The chimney

If local regulations permit, the stove may be connected to a chimney already serving another fireplace (such as an oil-burning stove or another wood-burning stove). Attention should be paid to any requirements concerning the location of flue pipes if two or more fireplaces are connected to the same chimney.

The wood-burning stove must never be connected to a chimney to which a gas-burning stove is already connected.

An efficient, modern stove places great demands on the chimney, so you should get the chimney sweep to evaluate chimney.

The aperture of the chimney must comply with national and local regulations. In general, the aperture area should measure at least 175 cm<sup>2</sup> (150 mm diameter) for wood-burning stoves.

An overly large chimney aperture will mean that too much energy will be required to heat the chimney sufficiently to achieve an acceptable draught in the chimney. If you have a brick chimney with a large aperture, we recommend that you install an insulating chimney liner of the proper diameter. This will increase the draught, and improve the fuel economy.

There are no requirements with respect to specific chimney heights, but a chimney must be tall enough to provide a good draught, and to ensure that the smoke does not cause any problems. As a general rule, there will be a satisfactory draught if the chimney extends 4 metres above the stove and at least 80 cm above the spine of the roof.

If the chimney is located along the side of the house, the top of the chimney should never be lower than the spine of the roof or the highest point on the roof. Please note that there are often national and local regulations concerning the location of chimneys in houses with thatched roofs. Please see section 1.9 on Draught.

The chimney and the flue pipe must be fitted with cleaning doors, which must be at least the same size as the chimney's aperture area.

The chimney must be accessible for external inspection, and it must be possible to access the cleaning doors and the chimney if it is to be cleaned from the top (e.g. steel chimneys).

## 1.6 Connecting the flue pipe

### Lift the upper cast iron top plate off the stove.

Note: the round cast iron cover plate in the top plate must remain mounted if the stove is being installed with the flue pipe to the rear, but unscrewed from the upper top plate if the flue pipe is being installed pointing upwards.

### Mounting the flue collar pointing upwards

From the factory, the stove is prepared for installation with the included flue collar (1) pointing upwards with included screws.

### Mounting the flue collar to the rear

With a hammer use light, firm taps to knock out the iron piece on the convection back panel from the small “bridges” holding the piece in place.

The cover plate for the smoke outlet is unscrewed from the back panel and the fixed onto the top panel.

Mount the flue collar onto the back panel. Lift the top panel back into place and the round section which is provided can be placed in the top panel and cover for the blocked off smoke outlet.

### The location of the baffle and cast smoke hood

The rear brick and the baffle (3), which are made from vermiculite, are mounted at the factory.

The baffle is lifted from its position and taken out of the stove. The casted smoke hood (2) is delivered loose in the stove and must be attached after installation of the stove.

The smoke hood is lifted and turned clockwise into place so it is locked in the two bolts at the upper flueoutlet

**Make sure that the baffle and rear brick stone are correctly assembled before lighting the stove (please see the sketch.)**

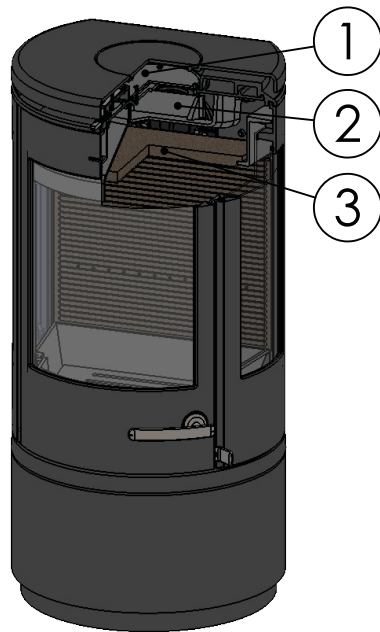

Morsø 7940

### Optional fresh air connection

The stove is factory prepared for installation of an optional fresh air connection independent of the room in which the stove is installed. The box for this fresh air connection, which can be purchased separately, enables a  $\varnothing 100\text{mm}$  pipe to be connected either to the rear or below.

However, this does not apply to the Morsø 7848/7948 pedestal stove and wall-hung Morsø 7870/7970.

## 1.7 Connecting to a brick chimney

Brick a flue bushing securely into the wall, and insert the flue pipe into it. The pipe must not extend into the actual chimney opening, but only to the inside of the chimney aperture. The joints between the stove/pipe and pipe/wall bushing must be sealed with the glass tape provided. It is not normally necessary to seal between any pipe joints.

If the flue pipe transitions from horizontal to vertical, it is a good idea to install it with a gentle bend so as to avoid any loss of draught.

The flue pipe must be dimensioned in accordance with national and local regulations. Morsø recommends, however, that flue pipes be made of 2 mm sheet steel, as this will extend the service life.

## 1.8 Connecting to a steel chimney

If your installation involves taking the chimney straight up and through the ceiling, you must comply with National, Local Building Regulations or flue manufacturers instructions concerning clearances to combustible materials such as walls, floor joists and ceilings. The joint between the stove flue collar and the stovepipe must also be sealed using the glass fibre rope provided. It is important that the insulated flue system is properly supported both at ceiling level and at roof level.

THE STOVE MUST NOT BEAR THE WEIGHT OF THE CHIMNEY SYSTEM (See chimney manufacturer's instructions). Excessive weight on the stove will inhibit expansion and could lead to damage of the stove top. Damage caused to the stove in this way would not be covered by the manufacturers guarantee.

If a chimney fire should occur as a result of incorrect operation of the stove or prolonged use of wet fuel, close the vents completely and contact the fire brigade.

## Installation of wall-mounted Morsø 7870/7970

The wall-mounting frame has holes for mounting expansion bolts into the wall.

**The bolts must be adequately sized and you must ensure that the wall is capable of supporting the stove. The weight of the empty stove is approx. 130 kg )**

It is therefore the responsibility of the installation contractor/customer to make sure that the wall/chimney can support the stove securely. We point out that element block chimneys and semi-brick chimneys without a lining do not always have the necessary carrying capacity. If in doubt, you should contact a professional craftsman. The wall mounting frame may be used as a template for drilling.

**Note: Plastic rawplugs must not used due to the heat produced by the stove.**

Minimum distance to combustible floor is 275 mm.

Mount the wall-mounting fixture on the wall. If the flue exit is wanted to the rear, build a wall bushing correctly into the wall.

Lift the wood stove in place so that it rests on the bottom part of the wall-mounting fixture, and secure it again to the fixture by means of the screws included.

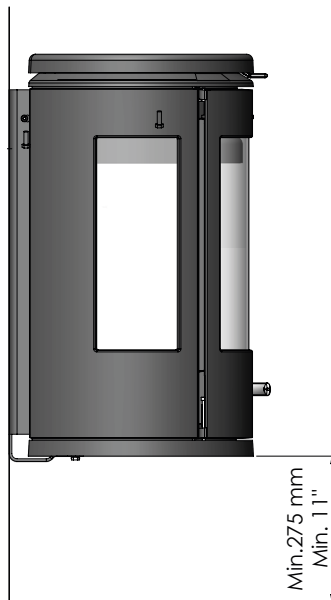
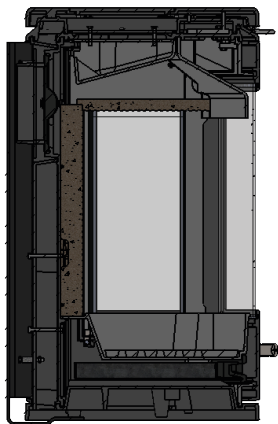

### Morsø 7970

#### **Be aware of the following:**

Discuss the cleaning options with your chimney sweep.

If there is insufficient draught in the chimney, it may be a good idea to install the flue pipe straight up, so as to minimise smoke migration in the actual combustion chamber.

Avoid having any more bends than necessary, and limit the length of the flue pipe so as not to reduce the draught.

#### **Fresh air supply**

A wood-burning stove requires air for combustion. As a result, firing a wood-burning stove will help to create a healthy climate in your house. If the house is very tightly sealed, and particularly if there is a cooker hood or ventilation system in the house, it may be necessary to install an air grate in the room in which the wood-burning stove is installed. Otherwise there may not be enough draught in the chimney, which may result in the stove not being able to burn properly, and smoke may come out of the stove when the fire door is opened. If it is necessary to install air grates, they must be positioned so that they cannot be obstructed.



## 1.9 Draught

If smoke comes out of the stove when the fire door is opened, it will be due to the poor draught in the chimney. This type of stove requires at least 12 pa. of chimney draught to achieve satisfactory combustion, and to prevent smoke from escaping. Smoke may, however, escape in any event, if the stove door is opened during very vigorous burning, so this should be avoided.

The flue gas temperature at the rated output is 283°C relative to 20°C.

If in doubt, you may want to get your chimney sweep to measure the draught in the chimney.

### **Draught**

The draught in the chimney is the result of the difference between the high temperature in the chimney and the cooler temperature outside. Other factors that determine whether enough negative pressure can be produced to create a draught include the length and insulation of the chimney, and wind and weather conditions.

#### **The draught will be reduced when:**

- The temperature difference is too low, e.g. in connection with a poorly insulated chimney. If the chimney is cold, it may help to light (burn up) a rolled-up newspaper in the chimney's cleaning door.
- The outside temperature is too high, for example during the summer.
- There is no wind.
- The chimney is not tall enough, with the result that it sits in the lee of the roof surface or tall trees. These conditions are also associated with the greatest risk of smoke coming back down the chimney.
- Air is entering the chimney in undesired places, e.g. through cracked joints or leaks in the cleaning door or the flue pipe.
- Unsealed, unused fireplaces are connected to the chimney.
- The flue pipe and chimney are clogged up with soot, due to inadequate cleaning.
- The house is too tightly sealed (please see the section on Fresh air supply).
- Too little air is getting in.

#### **A good draught is achieved when:**

- There is a big difference between the temperature in the chimney and outside during firing, i.e. when the need for heating is greatest.
- The weather is clear and there is a good wind.
- The chimney is of the proper height, i.e. at least 4 metres above the stove, and clear of the spine of the roof.

## 2.0 Firing/using the stove

### **Your stove is constructed with air inlets in three places.**

Pre-heated combustion air from beneath the grate. This combustion air should only be used during start-up and only if chimney conditions is bad or the fuel is a bit moist. The controller handle for this combustion air is placed on the back of the stove

A second pre-heated, fast-moving combustion air is added to the fire above the glass window, and is regulated using the handle above the door. The combustion air is let in when the handle is pushed to the right, and shut off when the handle is pushed to the left.

A third air inlet provides a constant, pre-heated air supply which cannot be adjusted, and which comes into the combustion chamber just above the fire. This helps to burn off the last few gasses emitted by the wood whilst it is being heated up.

### **N.B!**

**Wood is a material that contains a great deal of gas (approximately 75 %). The gases are released when the wood is lit and heated up. For this reason, it is important that the gases are ignited quickly after stoking. If the wood just lies smouldering, especially after re-stoking, a lot of smoke is created, which, in the worst case, may cause an explosive ignition of the gasses, resulting in damage to the stove.**

In order to ignite the gases that are released from the wood, and to keep clear, lasting flames during the combustion process, it is important to let in the required quantity of oxygen (air supply) at all times. The setting of the air supply, the method of ignition and the lighting intervals depend on the draught in the chimney, the wind and weather, the amount of heat required, the fuel, etc. This means that it may take some time before you get to know the correct functioning of the stove under any given circumstances.

Although you can fire your Morsø stove with almost all kinds of wood, you should not fire with wet wood, or unseasoned wood. Wood ought to be stored under a roof for at least 1 year, and preferably 2 years, with free access to wind. Wood should be chopped as soon as possible after felling if it is to dry quickly. The wood can be used once the moisture content is less than 20%. During the EN test, all stoves are tested with wood with a moisture content of  $(16 \pm 4)\%$ .

Never use driftwood, as it usually has a high salt content, which damages both the stove and the chimney. Impregnated and painted wood and chipboard emit poisonous smoke and fumes, so they should not be used as fuel either.

Please note that liquid fuel may not be used in the stove.

Pieces of wood with a diameter greater than 10 cm should always be chopped.

The pieces of wood should be short enough to be able to lie flat over the layer of embers, with air at both ends.

The maximum length of fuel in the stove is 30 cm. The maximum quantity of fuel is 2 kg/hour (max. 2 pieces of wood each time you re-stoke).

The first few times you light the stove, the fire should be moderate, so that the heat-resistant paint can harden before firing more vigorously. During the hardening phase, the paint may develop obnoxious smoke and smell the first time it is lit, which is very normal. Make sure that the room is well ventilated during this period.

When heating up or cooling down, the material is exposed to major temperature differences that may cause the stove to give off creaking sounds.

## 2.1 Lighting and fuelling intervals

A lot of air is needed when lighting the stove. If you are starting with a cold stove, the door should be left ajar for the first few minutes, and the combustion air supply opened to maximum. Always keep a couple of centimetres of ash in the bottom of the combustion chamber. This will have an insulating effect, and ensures good combustion.

1. A layer of embers will form rapidly if the stove is lit with 2 fuel tablets or 7 - 10 rolled up sheets of newspaper underneath 2 kg of dry kindling.



2. Open the air supply as much as possible. This is done using the handle above the door.



3. After the paper/solid alcohol tablets have caught fire, leave the fire door ajar, so that the chimney draws well.



4. When you can see that the chimney is hot enough to draw (after 5 - 10 minutes), close the door. If all the necessary conditions are met, a thick layer of embers will have been formed in the combustion chamber after another 15 - 20 minutes, and there will be a high temperature in the combustion chamber, which is necessary in order to be able to continue the combustion.



- If the condition in step 4 is met, place max. 2 pieces of wood with a total weight of 1.5-2 kg and a length of 25-30 cm over the embers in a single layer, with a distance of approximately 1 cm.



- Open the air supply to maximum, and close the door. The fresh wood will be lit within 1-3 minutes. If it does not light, open the door slightly to allow in enough air to ignite the wood. Close the door again once the wood has caught.



### **Important!**

**It is important that the fresh quantity of wood starts to burn quickly. To ensure the fuel lights quickly, open the combustion air to max. or leave the door ajar to allow in the amount of air needed to light the wood.**

**If, however, the wood only smoulders, there will be a strong build-up of smoke, which at worst can cause an explosive ignition of the flue gases with the risk of material damage and personal injury.**

- Reduce the amount of combustion air to the desired position, and the optimal combustion will continue. Make sure that there is always enough air (oxygen) to maintain clear, lasting flames when, and after, reducing the amount of combustion air.



**Make sure that there is always enough air (oxygen) to maintain clear, lasting flames when, and after, reducing the amount of combustion air.**

The stoking interval is between 45-75 minutes.

- Once the fire has been reduced to a thick layer of embers, a new portion of wood can be added by repeating steps 5 & 7.



The stove door must be opened gently the first 2 - 3 centimetres, then you should wait until the pressure has equalised before opening the door all the way. This technique will prevent smoke from getting out, particularly when there is a poor draught.

**The stove door should never be opened when the stove is being fired vigorously.**

Once the wood has burned out, it becomes glowing charcoal. If a good layer of embers has already formed on top of a sufficient layer of ash, the stove can keep warm for a very long time, not least due to the favourable qualities of the cast iron.

## **Precaution with the use of Morso 7800/7900 in Smoke Control Areas**

The 7800/7900 has been recommended as suitable for use in smoke control areas when burning wood logs with less than 20% moisture.

- **Refuelling on to a low fire bed**

If there is insufficient burning material in the firebed to light a new fuel charge, excessive smoke emission can occur. Refuelling must be carried out onto a sufficient quantity of glowing embers and ash that the new fuel charge will ignite in a reasonable period. If there are too few embers in the fire bed, add suitable kindling to prevent excessive smoke.

- **Fuel overloading**

The maximum amount of fuel specified in this manual should not be exceeded, overloading can cause excess smoke.

- **Operation with door left open**

Operation with the door open can cause excess smoke. The appliance must not be operated with the appliance door left open except as directed in the instructions.

- **Dampers left open**

Operation with the air controls or appliance dampers open can cause excess smoke. The appliance must not be operated with air controls, appliance dampers or door left open except as directed in the instructions.

We would strongly recommend that you do not leave your stove alit at night. It harms the environment, and constitutes very poor use of the wood, as the gases in the wood do not ignite at the low temperature, but settle as soot (unburned gases) in the chimney and stove. Extreme conditions, such as poor draught in the chimney, large quantities of wood or wet wood, may, in the worst-case scenario, cause an explosive ignition.

When firing in the summer period, when there is minimal need for heat, the combustion will be poor. The stove provides too much heat, so the combustion should be reduced. But always remember to make sure that there are lasting flames until the wood becomes charcoal. If you want a weaker fire, stoke up using less wood.

If you fire the stove using wet wood, a lot of the fuel's thermal energy will be spent forcing the water out of the wood, without releasing any heat to the stove. This incomplete combustion results in a layer of soot being left in the stove, pipe and chimney.

#### Comparison between firing with wood and oil

Type of wood (moisture content 20%)	No. of cubic metres per 1000 l oil
Oak	7.0
Beech	7.0
Ash	7.2
Sycamore	7.5
Birch	8.0
Elm	8.9
Common spruce	10.4
Silver fir	10.9

The stove's rated heat output is 7.3 kW. Your new Morsø stove is EN-tested for firing with wood, and is suitable for intermittent use.

## 3.0 Routine stove maintenance

### 3.1 External maintenance

The cast surface of the stove is painted with heat-resistant Senotherm paint. It is best maintained by simply vacuuming it with a soft brush attachment or wiping it down with a dry, dust-free cloth.

If the stove is used too vigorously, the painted surface may assume a greyish tinge over time, but the stove can easily be freshened up with Morsø spray paint, which is available from your local retailer. Morsø stoves are painted using a Morsø Original Black (previously called Morsø dark grey) or Morsø grey. The paint can be bought in a spray or a can.

### 3.2 Internal maintenance

**A few drops of mineral oil applied to the door latch may be required from time to time if it becomes difficult to open or close the door.**

Please see the drawing below:

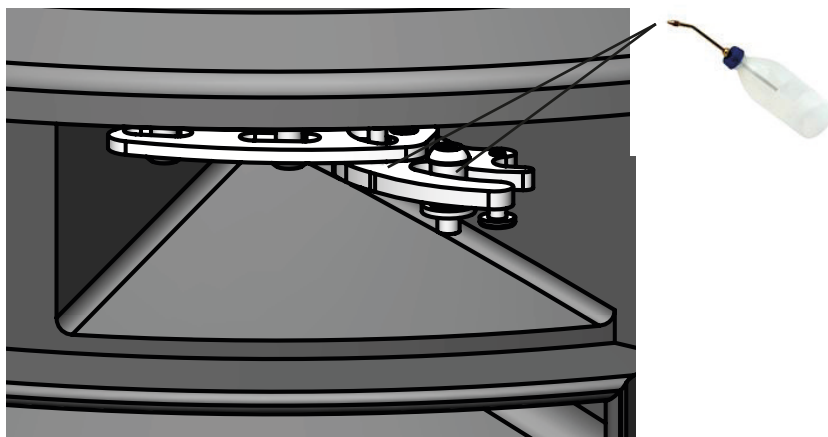

#### Glass window

If the stove is used correctly, very little or no soot will be deposited on the ceramic glass window. If soot does form on the glass as the stove is being lit, it will burn away once normal combustion begins in the stove. If the glass window becomes thoroughly covered in soot due to incorrect operation, the soot can be easily removed using Morsø Glass Cleaner. The glass must be cold when you clean it. Avoid stoking the stove with pieces of wood that are so long that they press against the glass window when the door is closed.

**Only use Morsø Glass Cleaner.**

#### Reasons for sooty glass window:

- The fuel is too wet
- The pieces of fuel are too big/uncut wood
- The combustion temperature is too low
- There is not enough air

#### Ceramic glass replacement

Ceramic glass cannot be recycled because it has a higher melting point than ordinary glass. If ceramic glass is mixed with ordinary glass, the raw material is spoiled, and the reclaiming process may be halted. Take care that the ovenproof glass does not end up among ordinary recycled waste.

That will be a great benefit to the environment.  
Note: Should be handed in to a recycling station as ceramic glass.

### **Internal cast-iron parts and/or wearing parts**

The baffles and other components that come in direct contact with the fire and glowing fuel are all wearing parts. As a result, they will be particularly susceptible to burn-through. When used correctly, these parts will last for many years, but overly vigorous use will naturally accelerate the burn-through. Such parts are all easily replaced. If the baffles are damaged and are not replaced in time, the top plate will be exposed to such high temperatures that it may be damaged as well.

**Please note that no unauthorised alterations of the design may be undertaken, and that any parts that are replaced must be replaced with original Morsø parts.**

#### **Reasons for overly rapid wear of internal parts**

- Stove fired too vigorously
- Use of very dry wood (wood from old furniture)
- Too much soot on top of the baffles (please see the section on Cleaning)
- Too much ash in the ash pan (please see the section on Ash)

### **Gaskets**

The gaskets in the door will wear out over time, and should be replaced as required in order to prevent runaway combustion. Use the original Morsø gasket kit.

**NOTE: Normal wearing parts are not covered by Morsø's extended warranty.**

A selection of maintenance products (spare parts, glass cleaner, paint, gasket kit, etc.) is available from your Morsø dealer.

## **3.3 Cleaning the stove**

A layer of ash and soot will form as a result of the draught in the chimney and after sweeping, particularly on the top of the casted smoke hood. This ash will have an insulating effect, which may speed up the burn-through of the baffle.

During normal cleaning, the baffle and the smoke hood can be removed from the stove. Once these parts have been taken out, you can access the flue chamber above the baffle and clean it.

Clean the baffle and smoke hood before reassembling them, and make sure that they are correctly assembled.

Nowadays the chimney sweep must remove the soot in the stove, in addition to sweeping the chimney and cleaning the flue pipe.

The number of annual sweepings/cleanings of the stove should be determined in consultation with your chimney sweep.

### **Ash**

As noted above, there should be a couple of centimetres of insulating ash in the bottom of the combustion chamber in order to achieve a high combustion temperature. If the layer of ash is too thick, it can be brushed down into the ash pan.

Empty the ash pan before it gets completely full, so that the ash does not insulate around the grate, and thereby speed up the burn-through.

In most cases, the ash will need to be taken away by the waste disposal company. Because embers may be concealed in the ash pan for several days, it may be necessary to store the ash in a container made of non-flammable material before pouring it into a rubbish bag.



## Spare parts for the 7800/7900

<b>Description</b>	<b>Product no.</b>
Cast grate	34791400
Cast smoke hood	34791800
Glass window, front	79790100
Glass window, outer side 7900	79790200
Glass window, inner side 7900	79790300
Vermiculite set 7800	79791400
Vermiculite set 7900	79790900



# Guarantee Product Registration

## MORSØ 10 YEAR GUARANTEE CERTIFICATE

Behind every Morsø stove is more than 160 years of dedicated stove design and manufacturing experience. Quality control has always been at the heart of the production process and detailed measures have been put into place at all key stages of the build. Accordingly, provided that the stove has been supplied by an authorised Morsø dealer, Morsø will offer a 10-Year Manufacturers Guarantee against manufacturing defect to any of the main exterior body parts of its stoves.

**Read more about "Morsø 10 years guarantee/product registration card" and  
REGISTER your new Morsø stove online:  
<http://international.morsoe.com/warranty-registration>**

## IMPORTANT!

### How to heat safely for the environment and yourself!

- **Use only dry wood**

Use only dry (max. 20% moisture content) and untreated wood. The fuel must be split and 8 - 12 cm thick.

- **Light**

Light with dry kindling (use 1 - 2 kg). Leave the door ajar and stay close to the stove during the lighting phase.

- **Good layer of embers**

Be certain to have a good layer of embers before refilling. The wood should light within 2 minutes. If the logs do not ignite it may, in an extreme case, cause the flue gases to ignite which may pose a risk to material damage or personal injury.

- **Refuelling**

When refuelling use 2 - 3 pieces of wood - no more than 2 - 2.5 kg.

- **Ensure adequate air**

i.e. clear and yellow flames.

- **Never burn overnight**



By appointment to The Royal Danish Court

# morsø

Morsø Jernstøberi A/S - 07.12.2021 - 72797500